

Installing and using a whole house fan

Why use a whole house fan?

A whole house fan is a simple and inexpensive method of cooling a house. The fan draws cool outdoor air inside through open windows and exhausts hot room air through the attic to the outside. The result is excellent ventilation, lower indoor temperatures, and improved evaporative cooling.

What are the benefits?

A whole house fan can be used as the sole means of cooling or to reduce the need for air conditioning. Outside air temperature and humidity dictate times when the whole house fan would be favorable over air conditioning. If both methods of cooling are present, a seasonal use of the whole house fan (during spring and fall) may yield the optimum combination of comfort and cost.

First cost benefit

Equipment cost for whole house fan = \$150 - \$350

Equipment cost for window unit AC = \$250 - \$750

Equipment cost for central AC = \$2,000 - \$4,000

Ventilation

A whole house fan can be used to change the air in the house and vent odors quickly.

Economics of operation

Operating a properly sized 2-ton, 10 SEER air conditioner in Atlanta, Georgia costs over \$250 per cooling season (1250 hours), based on 8.5¢/kwh, or roughly 20¢ per hour of runtime. A large 18,000 Btu/hr window unit air conditioner with a 6 EER costs more than 25¢ to operate for one hour.

By contrast, the whole house fan has a motor in the ¼ to ½ hp range, uses between 120 to 600 watts, and costs around 1-5¢ per hour of use.

What are the drawbacks?

Temperature, humidity, and dust

A whole house fan has some drawbacks: the fan can only cool the inside of a house to the outside temperature; unlike an air conditioner, it does not dehumidify; and dust and pollen can be brought into the house.

Maximize your savings

During the winter months (and summer when air conditioning is used), a whole house fan represents a potential energy loss because it is essentially a large, uninsulated hole in the ceiling. Standard fan louvers do not insulate or seal tightly.

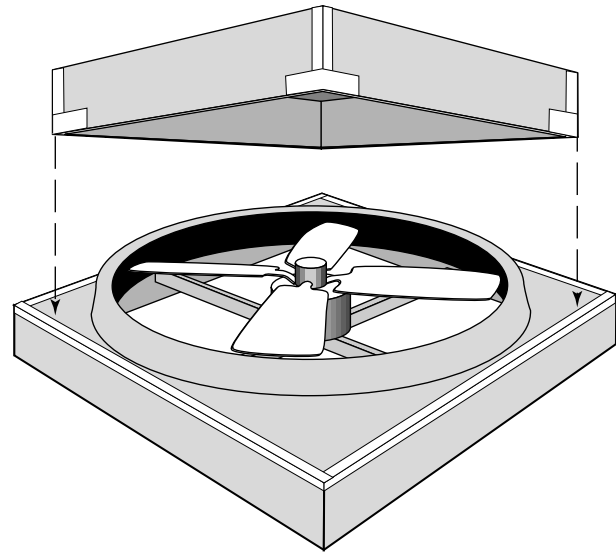

Whole house fan with attic-side cover. Whole house fans have either a direct drive motor (pictured) or a belt and pulley drive to turn the fan blades.

Build and use fan covers

See diagrams for construction details.

Because the louvers are leaky, a cover should be constructed to airseal and insulate this hole during the seasons when the fan is not in operation. The cover may be installed from the attic side if attic access is easily available or from the house side. Both covers could be included in excessively hot or cold climates. Homeowners must remember to remove cover(s) before operating the fan and to replace cover(s) during seasons when the fan is not in use.

Cooling strategies

In the summertime, the air inside a home is heated during the hot part of the day. At night especially, and during the morning and late evening, the outside air is often cooler and can be used to replace the inside air. It is important to open all or at least several windows, even if only partially, to provide adequate airflow. Closing windows in unused rooms will create higher velocity air movement in occupied rooms.

Running the whole house fan whenever outdoor temperatures are lower than indoor will cool the house. Operate the whole house fan throughout the evening to cool interior materials. An approximate rule of thumb would be to use the whole house fan when outside temperatures are below 85°F. As daytime temperatures rise, turn off the whole house fan. The cool room materials (along with ceiling or circulating fans which create an additional cooling effect) will help keep the interior more comfortable.

Installing a whole house fan

Use house wrap tape, spray foam, or caulk to seal fan frame to truss frame

Truss chord mounting bracket
Line up brackets
Do not cut truss chord

Airseal any gaps between fan box and truss frame so that when fan is running, no attic air is pulled across the fan.

Construct "H" brackets from 2x4's to create frame support for fan (see detail on next page)

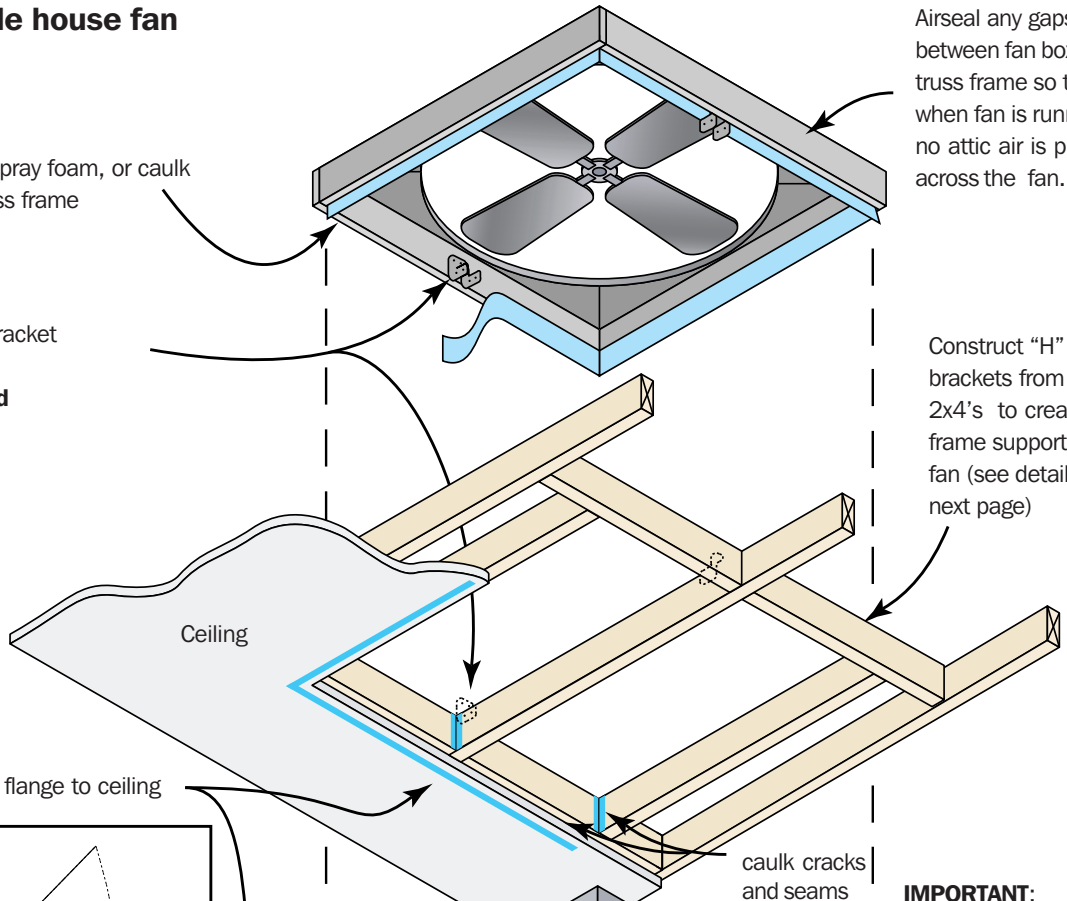

Caulk to seal louver frame flange to ceiling

caulk cracks and seams

IMPORTANT: Ensure louvers function properly (no binding or sticking)

Louver cover detail

1/4"-20 nut threaded all the way up to hold bolt to the louver section. Wing nut and washer hold rigid board insulation tightly against louver.

BOLT
LOUVER WITH HOLE
NUT
RIGID BOARD
WASHER
WING NUT

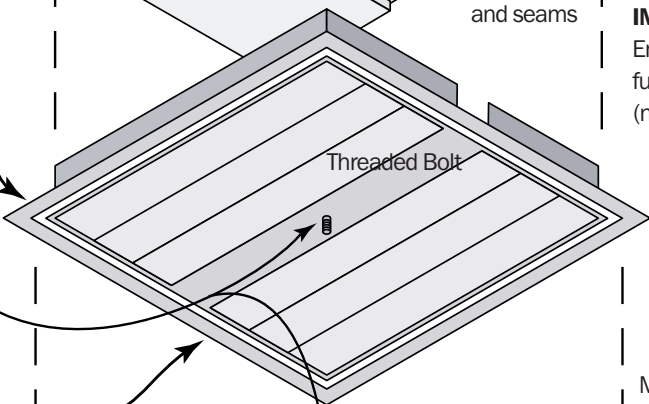

VELCRO™ - Helps to seal and attach cover used in winter

Louver cover materials list:

- 30" x 30" piece of 3/4"- 1" rigid insulation (minimum thickness)
- White contact paper
- Drill with 1/4" bit
- 1 1/4" long, 1/4" - 20 threaded bolt
- Fender washer with 1/4" opening
- 1/4" - 20 wing nut
- VELCRO™ with adhesive fasteners

Mount cover to louver with VELCRO™ and bolt with washer and wing nut

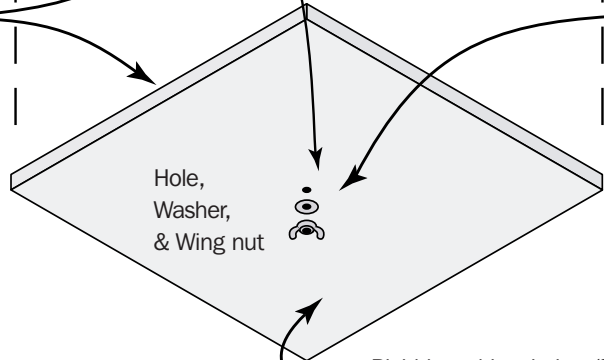

Rigid board insulation (3/4" - 1" thick) covered with white contact paper

How to build an attic-side box cover

A typical whole house fan has a 30" diameter blade with a sheet metal cowling of 31" to allow for blade clearance. An attic-side box cover may be constructed from a 4' x 4' piece of 1" rigid fiberglass duct board. The box will be 33" square with 1" thick walls (inside dimension of 31" x 31"). It will be 6½" deep. Adjust dimensions to actual fan size.

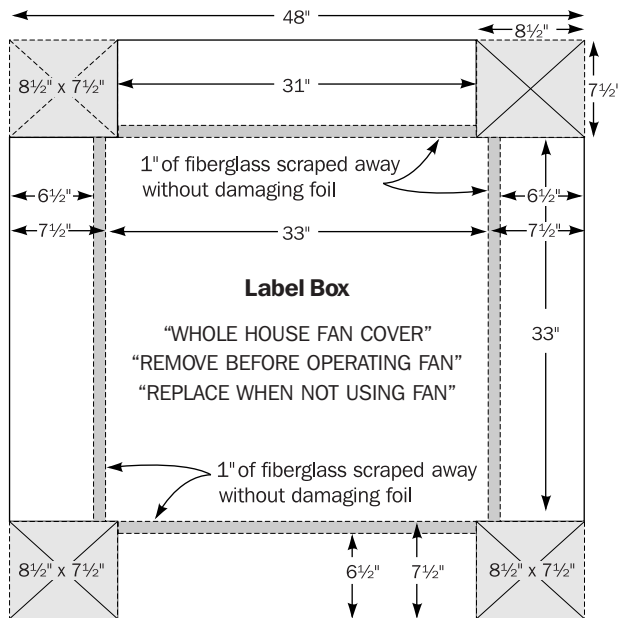

Cut out and discard four corners

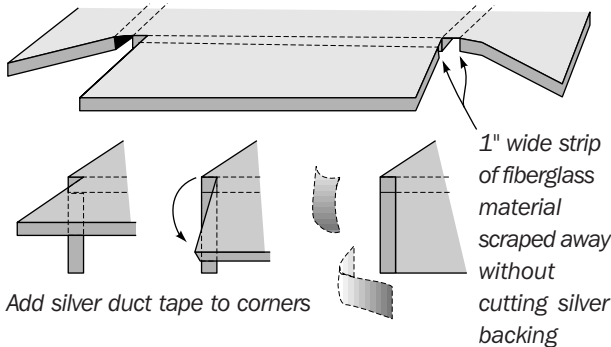

Attic-side box cover materials list:

- 48" x 48" piece of 1" fiberglass duct board
- Silver duct tape or house wrap tape
- Tools: measuring tape, straight edge, utility knife
- Permanent marker to label box
- Wear gloves and eye protection when working with duct board

Use "H" brackets to provide proper support

When installing a whole house fan, be sure to provide proper support and seal the unit into the rough opening in the ceiling. Never cut a truss chord; wooden "H" brackets installed between the trusses create a framed box to raise the fan above the truss system. The louvers must be able to operate freely (open/close) and care must be undertaken to prevent binding or misalignment.

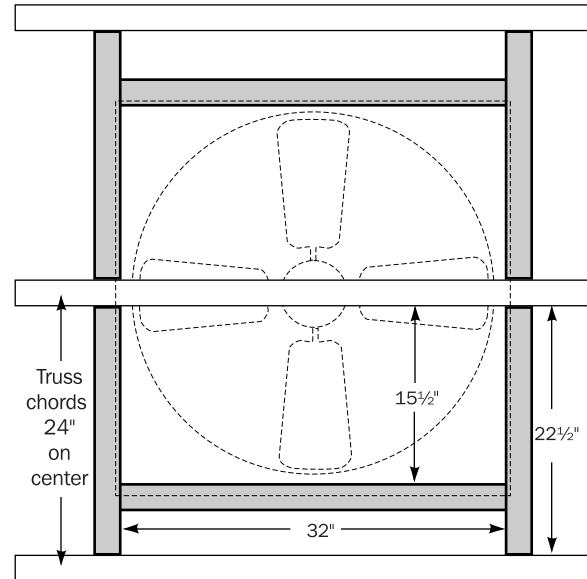

"H" brackets make fan installation easy. A fan with a 34" base (30" blade) will work with the dimensions shown

Helpful reminders

Attach labels to remind users to remove energy-saving covers.

Label the attic-side box cover

"WHOLE HOUSE FAN COVER",
"REMOVE BEFORE OPERATING FAN",
"REPLACE WHEN NOT USING FAN".

Label the fan switch

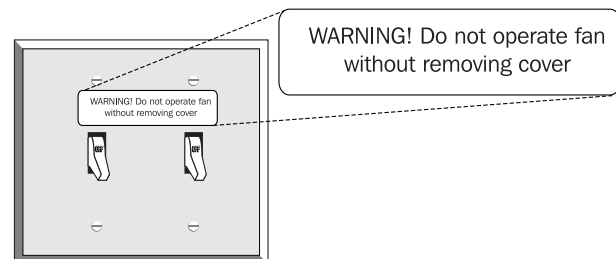

Selecting a whole house fan

☑ Fan speed

Two-speed fans permit the entire house to be ventilated quickly on high speed (such as when the occupants first arrive at home) and then provide gentle air circulation at the lower, quieter speed. Variable speed units offer more flexibility in selecting the desired air movement.

☑ Control options

Controls may be simple on/off pull or wall switches, multi-speed rotary wall switches, or a timer which automatically shuts off the fan at pre-selected time intervals.

☑ Louvers

Dampers or louvers typically operate automatically whenever the fan operates. Motorized dampers are available but are not necessary if the louvers are correctly installed and maintained. Proper opening and closing of louvers is critical to a whole house fan's performance.

☑ Motor mounts and noise

A direct drive unit has its fan blades attached directly to the motor's shaft. It is usually less expensive to buy and operates at higher rpm's than its belt driven counterpart. A belt driven unit, which typically features a motor driving a slower moving, larger diameter fan with four or more blades, may be quieter, but will require maintenance of the pulley and belt.

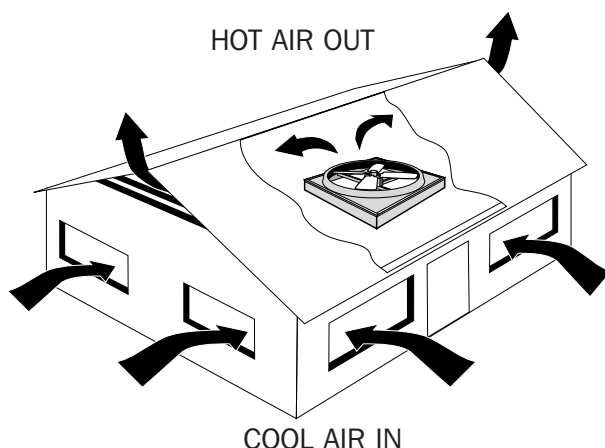

In addition to sizing a whole house fan correctly, it is important that ALL penetrations between the attic and living space are sealed and that the attic is properly ventilated. A central hallway, or a stairway in a two-story house, is the most common location.

Sizing a whole house fan

Determining the amount of airflow in cubic feet per minute (cfm) that the whole house fan should provide involves a simple calculation. Multiply the total gross square footage of the house (include upstairs area) by the ceiling height (typically 8 feet). Select a fan that delivers between one half to one times that amount of cfm at 0.1" static pressure. For example, a 25'x40', one-story home is 1,000 square feet and would need an $8 \times 1,000 \times \frac{1}{2} = 4,000$ cfm fan or better. A manufacturer sells a two-speed unit that delivers 4,500 cfm at the high setting (240 watts) and 3,200 cfm at low (120 watts); this unit should be adequate.

Installation tips and concerns

☑ Seal penetrations and vent attic adequately

Caulk all penetrations between the attic and living space, i.e., electrical boxes for ceiling light fixtures, loose attic hatches, large cutouts for plumbing vents, exposed beams, and recessed lights. A whole house fan creates a positive pressure in your attic and it is important that air from the attic is not forced back into the living space through cracks and gaps.

Guidelines for sufficient attic vent area is one square foot of net free vent area per 750 cfm of fan airflow, ($4,500 / 750 = 6$ square feet for the example above). Continuous ridge and soffit vents are usually more than adequate. Vents with insect screens may have a net free area equivalent to $\frac{1}{2}$ of the total open area depending upon the size of the holes in the screen area. Insulation should be installed directly against the fan box frame. Blown-in insulation may require the sides of the fan box to be raised (with baffles) to prevent interference.

☑ Avoid backdrafts

Care should be taken to avoid backdrafting combustion appliances that are installed in the conditioned space. It is strongly recommended that combustion appliances NOT be installed in such a manner that they use room air for combustion. The whole house fan is capable of pulling large quantities of air from the home and, particularly if not enough windows are open, may easily backdraft a water heater located inside a louvered closet door.

☑ Label your switches

Controls should be placed higher on walls than light switches to avoid confusion and to keep them out of the reach of small children. Labels over switches are recommended to remind users to remove any energy-saving covers and to open at least two or more windows before using.