



Buildings for the 21st Century

Buildings that are more energy-efficient, comfortable, and affordable...that's the goal of DOE's Office of Building Technology, State and Community Programs (BTS). To accelerate the development and wide application of energy efficiency measures, BTS:

- Conducts R&D on technologies and concepts for energy efficiency, working closely with the building industry and with manufacturers of materials, equipment, and appliances
- Promotes energy/money saving opportunities to both builders and buyers of homes and commercial buildings
- Works with State and local regulatory groups to improve codes, standards, and guidelines for efficient energy use
- Provides support and grants to States and communities for deployment of energy-efficient technologies and practices



WHOLE HOUSE FAN

How to install and use a whole house fan

WHY USE A WHOLE HOUSE FAN?

A whole house fan is a simple and inexpensive method of cooling a house. The fan draws cool outdoor air inside through open windows and exhausts hot indoor air through the attic to the outside. Running a whole house fan whenever outdoor temperatures are lower than indoor temperatures will cool a house.

In summer, the air inside a home is heated during the hot part of the day. During the morning, late evening, and night, the outside air is often cooler and can be used to replace the inside air. Operating the whole house fan at these times will cool interior materials. As daytime temperatures rise, the whole house fan can be turned off. The cool materials (along with ceiling or circulating fans, which create an additional cooling effect) will help keep the interior more comfortable.

WHAT ARE THE BENEFITS?

A whole house fan can be used as the sole means of cooling or to reduce the need for air conditioning. If both methods of cooling are present, seasonal use of the whole house fan (during spring and fall) may yield the optimum combination of comfort and cost.

✓ INITIAL COST BENEFIT

- Equipment cost for whole house fan = \$150–\$350
- Equipment cost for window unit AC = \$250–\$750
- Equipment cost for central AC = \$2,000–\$4,000

✓ ECONOMICS OF OPERATION

- Operating a properly sized 2-ton air conditioner with a seasonal energy efficiency ratio (SEER) of 10 in Atlanta, Georgia, costs over \$250 per cooling season (1,250 hours), based on 8.5¢/kWh, or roughly 20¢ per hour of runtime.
- A large 18,000 Btu/h window unit air conditioner with an energy efficiency ratio (EER) of 8.8 costs more than 17¢ to operate for one hour.
- By contrast, a whole house fan has a motor in the ¼ to ½ hp range, uses between 120 to 600 watts, and costs around 1¢ to 5¢ per hour of use.

MAXIMIZE YOUR SAVINGS WITH FAN COVERS

During the winter months (and in summer when air conditioning is used), a whole house fan represents a potential energy loss because it is essentially a large, uninsulated hole in the ceiling. Since standard fan louvers do not insulate or seal tightly, a cover should be constructed to airseal and insulate this hole (see diagrams on pages 2 and 3 for construction details). The cover may be installed from the attic side (if attic access is easily available) or from the house side. Covers for both sides could be included in excessively hot or cold climates. Homeowners must remember to remove cover(s) before operating the fan and to replace cover(s) during seasons when the fan is not in use.

INSTALLATION TIPS AND CONCERNS

SEAL PENETRATIONS AND VENT ATTIC ADEQUATELY

Caulk all penetrations between the attic and living space, such as electrical boxes for ceiling light fixtures, loose attic hatches, large cutouts for plumbing vents, exposed beams, and recessed lights. A whole house fan creates a positive pressure in the attic; it is important that air from the attic is not forced back into the living space through cracks and gaps.

A guideline for sufficient attic vent area is one square foot of net-free vent area per 750 cfm of fan airflow ($4,500 / 750 = 6$ square feet for the example described on page 4). Continuous ridge and soffit vents are usually more than adequate. Vents with insect screens may have a net-free area equivalent to one-half of the total open area, depending upon the size of the holes in the screen area. Insulation should be installed directly against the fan box frame. Blown-in insulation may require the sides of the fan box to be raised (with baffles) to prevent interference.

INSTALLING A WHOLE HOUSE FAN

Use house wrap tape, spray foam, or caulk to seal fan frame to truss frame

Line up truss chord mounting brackets
DO NOT CUT TRUSS CHORD

Caulk to seal louver frame flange to ceiling

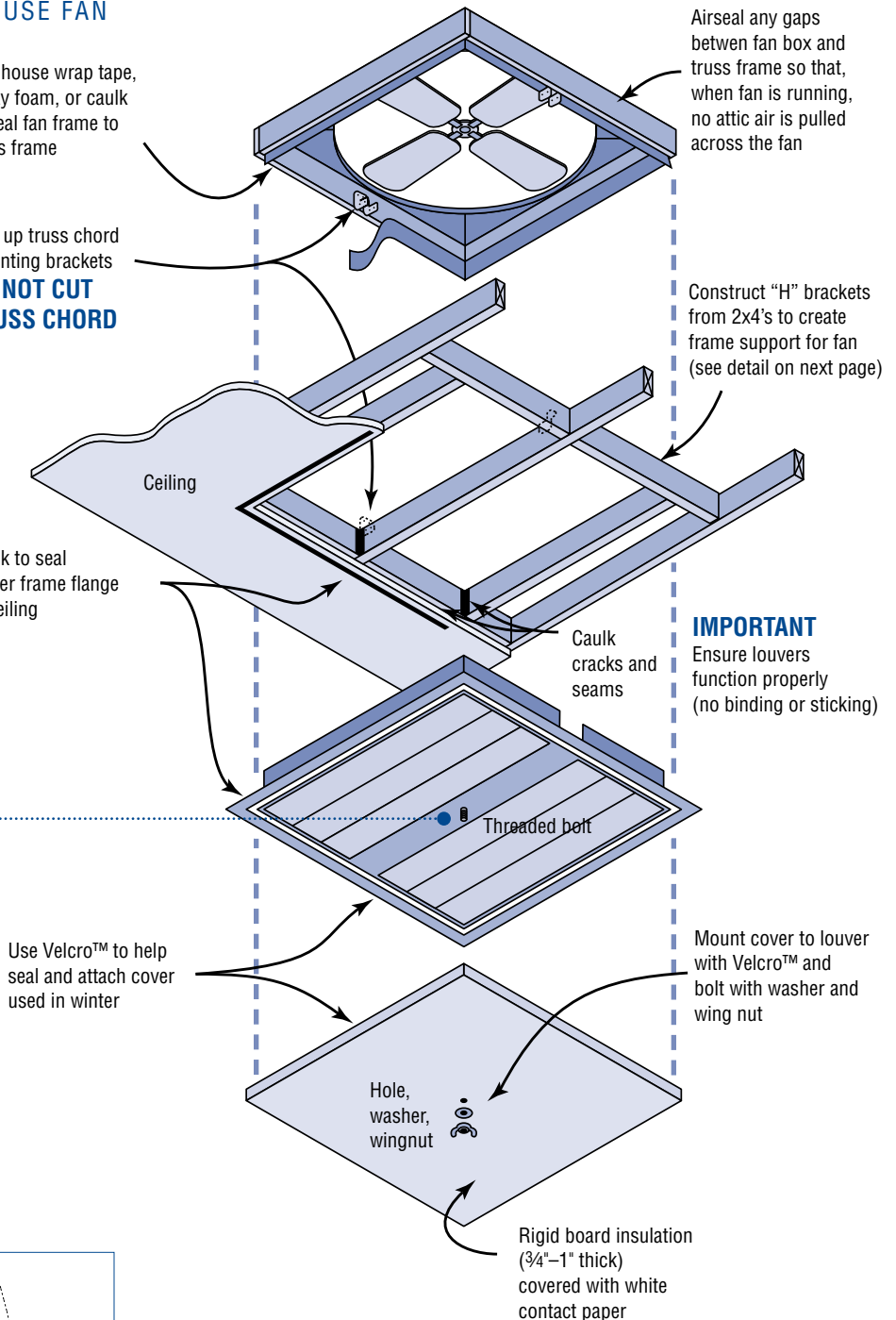

LOUVER COVER DETAILS

1/4"-20 nut threaded all the way up to hold bolt to the louver section. Wing nut and washer hold rigid board insulation tightly against louver.

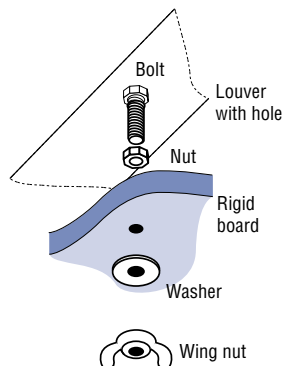

• Louver Cover Materials List

- 30" x 30" piece of 3/4"-1" rigid insulation (minimum thickness)
- White contact paper
- Drill with 1/4" bit
- 1 1/4" long, 1/4"- 20 threaded bolt
- Fender washer with 1/4" opening
- 1/4"- 20 wing nut
- Velcro™ with adhesive fasteners

WHOLE HOUSE FAN

"H" BRACKETS

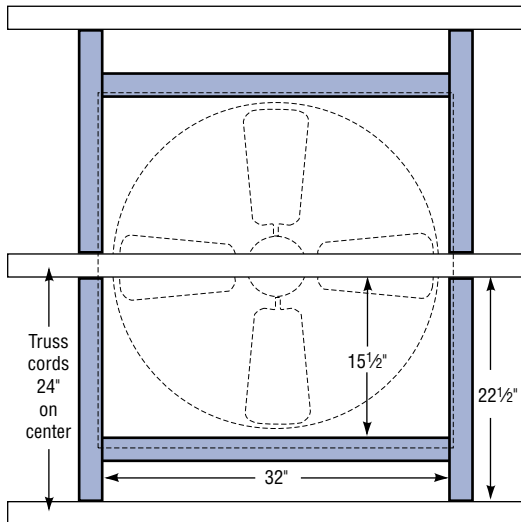

✓ USE "H" BRACKETS TO PROVIDE PROPER SUPPORT

When installing a whole house fan, be sure to provide proper support and seal the unit into the rough opening in the ceiling. Never cut a truss chord; wooden "H" brackets installed between the trusses create a framed box to raise the fan above the truss system. The louvers must be able to open and close freely and care must be taken to prevent binding or misalignment. A fan with a 34" base (30" blade) will work with the dimensions shown in the diagram at left.

✓ BUILD AN ATTIC-SIDE BOX COVER

A typical whole house fan has a 30" diameter blade with a sheet metal cowl of 31" to allow for blade clearance. An attic-side box cover may be constructed from a 4' x 4' piece of 1" rigid fiberglass duct board. The box will be 33" square with 1" thick walls (inside dimension of 31" x 31"). It will be 6 1/2" deep. Adjust dimensions to actual fan size.

Attic-side box cover materials list:

- 48" x 48" piece of 1" fiberglass duct board
- Silver duct tape or house wrap tape
- Tools: Measuring tape, straight edge, utility knife, permanent marker to label box
- Note: Wear gloves and eye protection when working with duct board

✓ AVOID BACKDRAFTS

Care should be taken to avoid backdrafting combustion appliances that are installed in the conditioned space. **It is strongly recommended that combustion appliances NOT be installed in such a manner that they use room air for combustion.** A whole house fan is capable of pulling large quantities of air from the home and, particularly if not enough windows are open, may easily backdraft a water heater located inside a louvered closet door.

ATTIC-SIDE BOX COVER

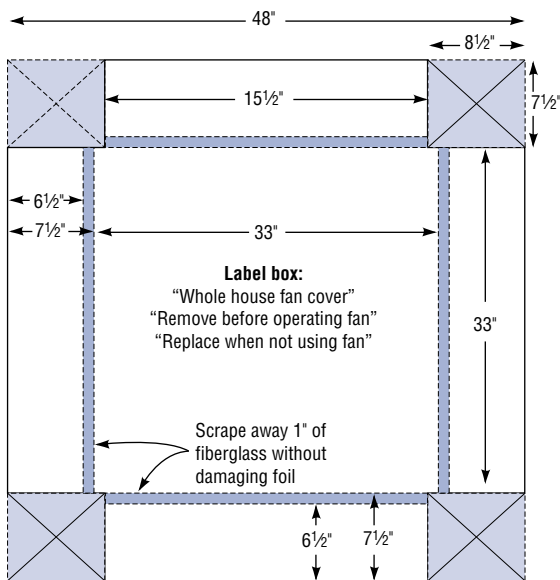

Cut out and discard four corners of fiberglass duct board

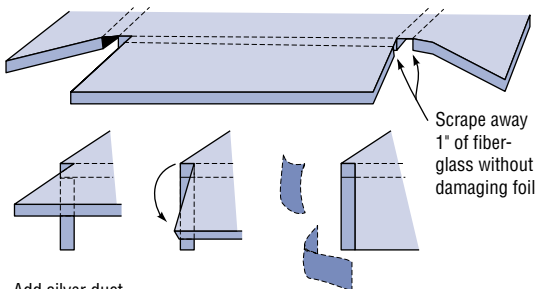

Add silver duct tape to corners

WHOLE HOUSE FAN

For more information,
contact:

**Energy Efficiency and
Renewable Energy
Clearinghouse (EREC)**
1-800-DOE-3732
www.eren.doe.gov

Or visit the *BTS* Web site at:
www.eren.doe.gov/building

Written and prepared for
the U.S. Department of
Energy by:

**Southface
Energy Institute**
404-872-3549
www.southface.org

**Oak Ridge
National Laboratory**
Buildings Technology Center
423-574-5178
www.ornl.gov/btc

NOTICE: Neither the United States government nor any agency thereof, nor any of their employees, makes any warranty, express or implied, or assumes any legal liability or responsibility for the accuracy, completeness, or usefulness of any information, apparatus, product, or process disclosed. The views and opinions of authors expressed herein do not necessarily state or reflect those of the United States government or any agency thereof.

SELECTING A WHOLE HOUSE FAN

- ✓ **FAN SPEED**
A two-speed fan permits the entire house to be ventilated quickly on high speed (such as when the occupants first arrive at home) and then provides gentle air circulation at the lower, quieter speed. A variable speed unit offers more flexibility in selecting the desired air movement.
- ✓ **CONTROL OPTIONS**
Control may be a simple on/off pull or wall switch, a multi-speed rotary wall switch, or a timer that automatically shuts off the fan at pre-selected time intervals.
- ✓ **LOUVERS**
Dampers or louvers typically operate automatically whenever the fan is on. Motorized dampers are available but are not necessary if the louvers are correctly installed and maintained.
- ✓ **MOTOR MOUNTS AND NOISE**
A direct drive unit has its fan blades attached directly to the motor shaft. This type of unit is usually less expensive to buy and operates at a higher speed than its belt-driven counterpart. A belt-driven unit typically features a motor driving a slower-moving, larger-diameter fan with four or more blades. It may be quieter, but will require maintenance of the pulley and belt.

SIZING A WHOLE HOUSE FAN

Determining the amount of airflow in cubic feet per minute (cfm) that the whole house fan should provide involves a simple calculation. Multiply the total gross square footage of the house (include upstairs area) by the ceiling height (typically 8 feet). Select a fan that delivers between one-half to one time that amount of cfm at 0.1" static pressure. For example, a 25' x 40' one-story home is 1,000 square feet and would need an $8 \times 1,000 \times \frac{1}{2} = 4,000$ cfm fan or better. A two-speed unit that delivers 4,500 cfm at the high setting (240 watts) and 3,200 cfm at low (120 watts) should be adequate.

HELPFUL REMINDERS

Label the attic-side box cover and the fan switch to remind users to remove energy-saving covers. Instruct occupants to open at least two or more windows before operation, especially windows in occupied rooms where cooling is desired.

WHOLE HOUSE FAN AIR FLOW

In addition to sizing a whole house fan correctly, it is important to ensure that all penetrations between the attic and living space are sealed and that the attic is properly ventilated. A central hallway, or a stairway in a two-story house, is the most common location.

